

C-1002

Banco modelo Zenit, dispone de 3 listones de madera tropical y pies en acero inoxidable AISI 304.
Dimensiones: 2016 x 560 x 770 mm.

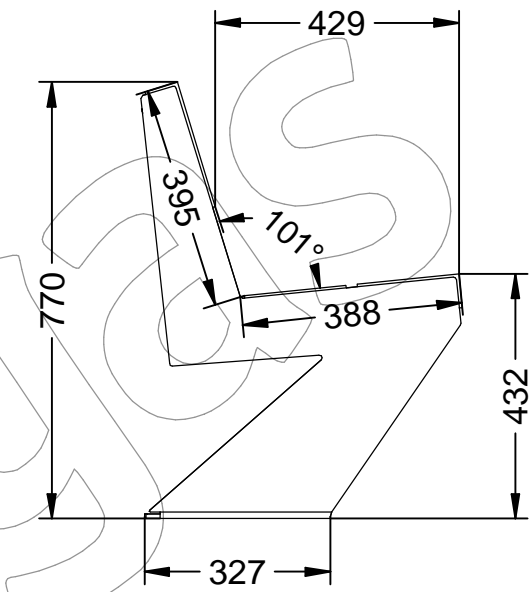
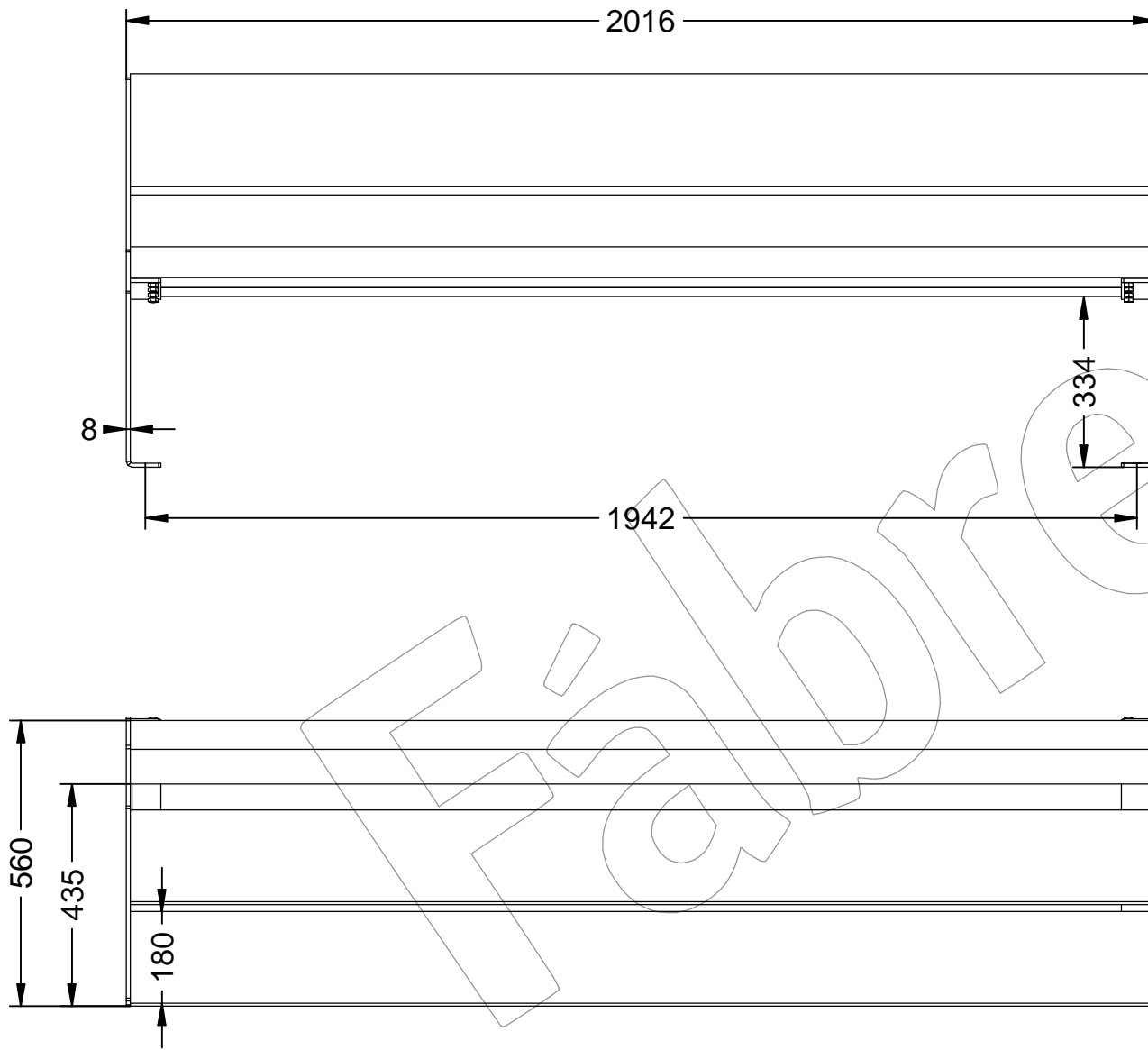

C-1002

Banco modelo Zenit, dispone de 3 listones de madera tropical y pies en acero inoxidable AISI 304.
Dimensiones: 2016 x 560 x 770 mm.



-ES- 

Descripción: Banco modelo Zenit, con 3 listones de madera tropical de 60 mm de espesor y patas en acero inoxidable AISI 304 con acabado pulido mate.

Materiales:

Pata: Acero inoxidable, AISI 304.

Listón: Madera tropical.

Acabados:

Pata: Pulido mate.

Listón: Barniz en poro abierto fungicida e hidrófugo.

Embalaje: Paletizado y plastificado.

Anclaje: Tornillo M10 x 100 mm (No suministrado).

-EN- 

Description: Zenit model bank, with 3 tropical wood slats of 60 mm thickness and stainless steel AISI 304 steel with finish matt polishing.

Materials:

Leg: Stainless steel, AISI 304.

Strip: Tropical wood.

Paint finish:

Leg: Matt polished.

Strip: Fungicidal and water-repellent open-pore varnish.

Packaging: Palletized and laminated.

Anchor: M10 x 100 mm screw (Not supplied).

-PT- 

Descrição: Zenit Model Bank, com 3 ripas de madeira tropical de 60 mm de espessura e aço inoxidável AISI 304 aço com acabamentoo Matt Polishing.

Materiais:

Perna: Aço inoxidável, AISI 304.

Faixa: Madeira tropical.

Acabamentos:

Perna: Matt polido.

Fita: Verniz de poros abertos fungicida e hidrorrepelente.

Embalagem: Paletizada e laminada.

Âncora: Parafuso M10 x 100 mm (Não fornecido).

-CA- 

Descripció: Banc model Zenit, amb 3 llistons de fusta tropical de 60 mm de gruix i potes en acer inoxidable AISI 304 amb acabat polit mat.

Materials:

Pota: Acer inoxidable, AISI 304.

Llistó: Fusta tropical.

Acabats:

Pota: Polit mat.

Llistó: Vernís en porus obert fungicida i hidrófug.

Embalatge: Paletitzat i plastificat.

Anclatge: Cargol M10 x 100 mm (No subministrat).

-FR- 

Description: Banque modèle Zenit, avec 3 lattes de bois tropical de Épaisseur de 60 mm et acier AISI 304 en acier inoxydable avec finition Matt Polishing.

Matériaux:

Pied: Acier inoxydable, AISI 304.

Lame: Bois tropical.

Finitions:

Pied: Poli mat.

Lame: Vernis à pores ouverts fungicide et hydrofuge.

Emballage: Palettisé et laminé.

Ancrage: Vis M10 x 100 mm (Non fournie).